

Instructions for Use

Absorbance 96

Valid for REF Number ABS MH A 01/ABS MH D 01

Software Version 1.1.0



Instructions for Use
Absorbance 96, Absorbance 96 App
Version 1.5 (2020-10-02)
©Copyright 2020 by Byonoy GmbH. All rights reserved.

Manufacturer: Byonoy GmbH
Bernstorffstr. 118
22767 Hamburg, Germany

00 49 40 5379 866 00
team@byonoy.com
www.byonoy.com

Dear customer,

We are delighted that you have chosen the Absorbance 96. To take full advantage of the instrument's performance and to enjoy your analysis instrument for many years, please read these instructions for use carefully before installation and commissioning. Operate the instrument in accordance with these instructions. The operating safety and function of the instrument can only be guaranteed if both general safety regulations and accident prevention regulations of the legislator as well as the safety instructions in this manual are regarded. We accept no liability for any damage resulting from improper use or incorrect operation.

- I Ensure that the manual is accessible at all times and is read and understood by all persons operating the instrument. Keep this manual in a safe place so that you can access it when necessary.**

- I The latest version of this manual (instructions for use) is available via the Absorbance 96 App. Upon request, a paper version can be shipped within 7 business days. Please use the contact form on the website.**

This user manual may only be used according to its intended purpose. It may not be reproduced, changed, or translated in another language without prior written consent of Byonoy GmbH.

This document is subject to technical changes and updates.

TABLE OF CONTENTS

1	General information	1
2	Instructions for using the Absorbance 96	3
2.1	Scope of application.....	3
2.2	Measurement method.....	3
2.3	About the Absorbance 96.....	3
2.4	Information on consumables	4
2.5	Power consumption	5
3	Preparing the product for use	6
3.1	Unpacking, storage and transport.....	6
3.2	Checking the supplied parts	6
3.3	Working environment	6
3.4	Software Installation Procedure & Updates.....	7
4	Operation	8
4.1	Connecting the Absorbance 96 with the computer	8
4.2	Setup an assay and create a protocol	8
4.3	Running the assay.....	14
5	Information required by the user	18
5.1	Explanation of the signal lights	18
5.2	Notes on troubleshooting	18
6	Maintenance and cleaning	20
6.1	Maintenance.....	20
6.2	Cleaning.....	21
6.3	Technical support	23
6.4	Repairs.....	23
7	Performance data and technical data	24
8	Guarantee	26
9	EC-Conformity Declaration	27

1 General information

Important: Follow the instructions for use

Any commissioning or handling of the instrument requires precise knowledge and notice of this manual. The device is intended for the described use only.

In this manual, particularly important remarks are highlighted as followed:

Warning:

!! This is a warning that indicates an immediate or potentially dangerous situation, which, if not avoided, will result in death or serious injury.

Caution:

! Caution indicates a potentially hazardous situation, which, if not avoided, could result in minor or moderate injury.

Information:

I This is a piece of information indicating certain characteristics that must be observed.

Liability for function and damage

Liability for the function of the device shall in any case pass to the owner or operator if the device is improperly maintained, repaired, or modified by persons who do not belong to the authorized service personnel, or if it is handled in a way that does not comply with its intended use. The service and operation of the product must be in accordance with this manual. Byonoy GmbH shall not be liable for damages resulting from non-observance of the information above. Warranty and liability conditions of the terms of sale and delivery of Byonoy GmbH are not extended by the information above.

Warning

- !!** An incorrect working environment can lead to a reduction in service life, damage to the device, or measurement errors. Please note the explanations and warnings in chapter 3.3.
- !!** To avoid measurement errors, it is essential to ensure that the instrument is connected properly and that the experiments are carried out correctly. Please note the explanations and warnings in chapter 3.
- !!** Incorrect cleaning of the instrument can reduce its service life and can cause damage to the instrument. Please note the explanations and warnings in chapter 6.2.
- !!** To avoid the risk of electric shock, do not expose the instrument to rain or excessive moisture and do not touch the instrument or USB cable with wet hands.

Information

- I Follow all safety instructions on the device and in the attached documents.
- I Follow all general precautions that apply to electrical instruments.

Disposal of used electrical and electronic equipment



The symbol on the product or its packaging indicates that this product is not to be treated as normal household waste. It must be disposed of at a collection point for the recycling of electrical and electronic equipment. By contributing to the correct disposal of this product, you protect the environment and the health of your fellow human beings. The environment and health are endangered by incorrect disposal. Material recycling helps to reduce the consumption of raw materials. For further information on how to recycle this product, please contact your local authority or municipal waste disposal companies.

Working with biological and harmful material

The Absorbance 96 is not to be used for the measurement of biohazardous substances.

Always observe the manufacturer's hazard information pertaining to the substances to be measured.

The instrument does not produce any toxic or harmful gases or substances. During the measurement, make sure that there are no toxic or harmful substances in the microtiter plate.

2 Instructions for using the Absorbance 96

2.1 Scope of application

The Absorbance 96 is an optical laboratory instrument for measuring the absorbance (optical density) of biological or non-biological samples in ANSI/SBS-standard 96-well microtiter plates in accordance with the specifications described in the user manual. The Absorbance 96 is intended for research and other non-in-vitro-diagnostic analyses only. It is to be operated by trained laboratory personnel and is intended for professional use.

2.2 Measurement method

The Absorbance 96 is designed to carry out fast and sensitive absorbance measurements. It measures the optical density (OD) of samples at defined wavelengths.

Absorption

Absorption refers to the amount of light absorbed by a medium. Absorption reduces transmission. Transmission is the ratio of incident to transmitted light. Accordingly, the degree of transmission is calculated as follows

$$T = (I/I_0)$$

where I is transmitted light and I₀ is incident light.

Optical Density

Optical density is a measure of the attenuation of light radiation after it has passed through a medium. Optical density is the logarithmic quantity that describes the reciprocal of the transmittance T:

$$OD = \log(I_0/I)$$

where I is the transmitted light and I₀ is incident light.

Optical density is the absorbance of the sample plus other attenuating effects such as scattered light due to turbidity. It is therefore necessary to avoid scattered light in order to measure absorbance correctly.

If no other attenuating effects are present, absorbance = optical density.

2.3 About the Absorbance 96

The Absorbance 96 is an absorbance-based measuring device, i.e. a measuring instrument, with which the absorbance values of a 96-well microtiter plate can be read, recorded and provided for further processing. The Absorbance 96 has 96 detection units, which allow measurement without a scanning mechanism.

In the upper part of the measuring instrument there are 4 light sources with different wavelengths and 4 interference filters. The four signal lights on the top of the reader show which measuring channel is being used for the current measurement.

The microtiter plate is inserted manually into the slot of the device. There are two raised locking-edges at the bottom of the slot, as well as an arrow for visual inspection that becomes wholly visible only after the microtiter plate has been completely inserted.

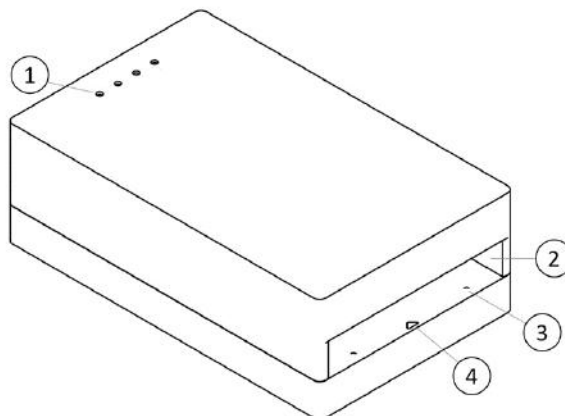

Figure 1. Visual representation of the product from the front, top. 1. Signal lights. 2. Slot for microtiter plate. 3. Raised locking-edges. 4. Arrow.

On the back of the Absorbance 96 is a USB plug for connecting the instrument to a computer via the included Micro-USB cable. Furthermore, there is an eject button for ejecting the microtiter plate out of the slot.

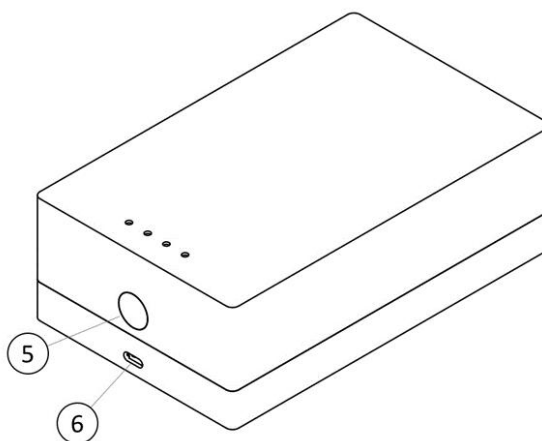

Figure 2. Visual representation of the product from behind, top. 5. Eject button. 6. Micro-USB plug.

2.4 Information on consumables

With the Absorbance 96, ANSI/SBS Standard 96-well microtiter plates can be read.

When using microtiter plates, always regard the specifications of the manufacturer of the microtiter plates. Not all microtiter plates of a manufacturer are the same in design, materials, or configuration. The temperature stability within the microtiter plate can depend on the type of microtiter plate used.

2.5 Power consumption

The Absorbance 96 is an analytical instrument with very low power consumption. It is operated by a Micro-USB cable and the total power consumption is generally less than 2.5 watts.

3 Preparing the product for use

3.1 Unpacking, storage and transport

Unpacking

Remove the packaging material and carefully place the unit on a firm and level surface. Check the product for external damage and check the parts supplied (see chapter 3.2).

The device is packed in a specially designed cardboard box. Keep the packaging material. If you return the device for repair, the original packaging material and box must be used.

Storage and protection during the intervals of normal use

!! Protect the device from moisture and dust during prolonged storage.

! Do not store the device next to heat sources and protect it from direct sunlight.

The storage temperature should be between 5°C and 40 °C.

Transportation

Before transportation, make sure that the device is disconnected from the computer and that it is turned off. Remove the cable from the instrument and make sure that there is no microtiter plate in the instrument. Depending on the transport distance, use the original packaging material. Make sure that the new location meets the requirements described in chapter 3.3.

! Always transport the product well packed to avoid possible transport damage.

!! Before transport, make sure that there is no microtiter plate in the instrument.

3.2 Checking the supplied parts

When unpacking the device, please check that the following components are present:

- Absorbance 96
- Micro-USB cable
- Hex key
- Microfiber cloth
- USB Stick

3.3 Working environment

Due to its small size, the Absorbance 96 can be operated very well in various working environments.

However, the following warnings must be regarded. Ignoring them may lead to a reduction in the expected lifetime, damage to the device, or measurement errors:

!! The device should stand on a level surface, free from dust and vibrations.

!! Do not operate the device near heat sources or under direct sunlight.

!! The ambient temperature should be between 5°C and 40°C.

!! The maximum humidity should not exceed 70%.

3.4 Software Installation Procedure & Updates

To install the Absorbance 96 App, insert the USB stick provided with the Absorbance 96 Reader into the computer and follow the steps below:

- Locate and select the USB drive in the document browser.
- Open the installation file either for Windows or macOS.
- Follow the steps in the Setup Wizard to complete installation.

I To install the proper drivers and software on the computer, the user must have administrator rights, or obtain such permissions.

I For Windows PCs: The computer must have at least windows 7 or above. Windows 10 and later versions function through plug and play. If an older version is being used, drivers may need to be installed. These are available on the USB stick provided with the device.

Uninstallation of software

The Absorbance 96 App can be uninstalled using the computer's standard uninstall procedure.

Updates

With Internet Access:

To check for new updates, click the update button in the menu bar. If an update is available, this will be shown in a bar at the top of the screen.

Without Internet Access:

1. Uninstall the current version of the software.
2. Load the update file using the link provided by Byonoy.
3. Open the file on the computer. The new software should now be installed.

4 Operation

Before commissioning the Absorbance 96, you should carefully read and understand the entire manual, so that you are familiar with the system.

4.1 Connecting the Absorbance 96 with the computer

! Place the instrument in a horizontal position secured against falling.

The Absorbance 96 requires a connection to the computer for power supply, to start the experiment, and for data transfer. Insert the Micro-USB cable into the Absorbance 96 and the USB port of the computer. The Absorbance 96 starts automatically when connected to a computer via the Micro-USB cable and the software automatically establishes a connection.

!! Always use the included Micro-USB cable for the connection to your computer.

I Connect the instrument directly to your computer and do not use an external USB hub.

I The device may only be operated at a USB port USB 2/USB 3 with 5 VDC and a maximum of 3 A of a certificated computer (with certification mark of an approved testing laboratory). Use an adapter cable on USB 3.1 with type C plug connection, which ensures the profile 1: 5 V@2.0 A.

When the Absorbance 96 is switched on, the signal lights on the top of the instrument light up. Each time the Instrument is switched on, an internal self-test is performed to ensure there are no malfunctions.

If no connection between the instrument and the computer is established, install the driver for the USB connection. You can find it in the supplied USB Stick. See chapter 3.4.

4.2 Setup an assay and create a protocol

Select "New" from the menu bar. Your experiment conditions can now be defined.

Name and Describe a Protocol

In the first section of the Setup Page you can name your assay/protocol. For the protocol you can additionally add a description, assign a supplier for the assay kit, or choose a logo.

Workflow Parameters

Wavelengths

Under "Wavelength", a signal and reference wavelength may be chosen.

The signal wavelength is the wavelength (in nanometers) at which the principal measurement will be run.

The reference wavelength is the wavelength (in nanometers) at which the reference is measured. The values measured at the reference wavelength will be subtracted from the values measured at the signal wavelength.

If no reference wavelength is desired, click the “None” button beside the reference wavelength.

Figure 3. Experiment Parameters

Readout Method

Under “Method”, the readout method can be selected.

In an “Endpoint” measurement, one measurement cycle is performed. Here you can choose between the different evaluation methods described below.

In a “Kinetic” measurement, you can set the parameters for multiple measurement cycles taken over a given time span.

- I To perform a signal-stable kinetic measurement, please ensure constant environmental conditions. I.e. constant ambient temperature and humidity.
- I For best results, acclimatize the connected reader and plate to the ambient temperature for at least 1 h.

I With kinetic measurements, a signal drift of about 1 mOD per hour might be observed.

Evaluation

The evaluation section allows you to choose which evaluative method will be used for the readout.

No Evaluation

No evaluation will be used. The raw OD values will later be shown in plate format.

Quantitative

- Upon selection of the Quantitative evaluation method, a second section titled "Fitting Method" will appear in the evaluation field.
- Click the drop-down menu and select one of the options: point-to-point, linear regression, 4-parameter or 5-parameter regression.
- The selected evaluation method will be used for the standard curve and the data analysis.

Qualitative

Upon selection of qualitative evaluation, the plate layout window will change and a formula for the cut-off definition will appear.

Terms for Cut-Off Definition

POS = the mean of the OD values of the positive control wells.

NEG = the mean of the OD value of the negative control wells.

CUT = the mean of the OD value of the cut-off control wells.

0 OD = zero. User defined value may be entered. See example 3.

Offset = the offset value for cut-off calculation.

Range = a percentage value defining a range beyond which the results are interpreted as either positive or negative.

The formula setup for the cut-off definition covers multiple formula types. These are listed below.

1. Cut-Off Value = Mean Neg. Controls +(-) k
2. Cut-Off Value = Mean Pos. Controls + k
3. Cut-Off Value = Mean CO. Controls + k
4. Cut-Off Range = [Mean (x)control + k] +/- x%

Where k is an experimentally determined factor normally defined by the laboratory professional or by the kit manufacturer.

Example 1: Subtraction

To replace the minus function, the user must simply enter a negative value. For example, if the cut-off is:

Cut-off = Mean Neg. Controls - 0.2
this must be entered as follows:

$$\text{Cut-off} = (\text{POS} \text{ NEG } \text{CUT} \text{ 0 OD} + [-0.2] \text{ OD}) \pm \text{Range} \%$$

Example 2: Range Definition

To define a range, you may use the “Range” field in the cut-off editor. This allows you to enter a percentage that will correspond to values above and below a given cut-off value, within which the experimental values will be deemed intermediate, above which positive, and below which, negative.

For example:

Sample is considered positive if: SampleOD > (Mean Pos. + 10%)

Sample is considered negative if: SampleOD < (Mean Pos. -10%)

Sample is considered intermediate if: (Mean Pos. - 10%) < Sample OD < (SampleOD + 10%)

This would be entered as follows:

$$\text{Cut-off} = (\text{POS} \text{ NEG } \text{CUT} \text{ 0 OD} + \text{Offset} \text{ OD}) \pm 10 \%$$

Example 3: Known Cut-Off Value

It may be the case that the cut-off value is known for a given experiment and need not be calculated. In this case, the “0 OD” option may be selected for the calculation and the desired value entered into the offset.

For Example: Cut-Off = 0.3

Then:

$$\text{Cut-off} = (\text{POS} \text{ NEG } \text{CUT} \text{ 0 OD} + 0.3 \text{ OD}) \pm \text{Range} \%$$

- I The examples shown in this manual do not represent actual data, rather function to clarify software features, and may not be referenced for experimental methods or procedure.

Plate Layout

In the plate layout section, the microplate can be filled out as desired.

Each well may be defined individually using the buttons below the plate.

- I The format of the plate layout and the corresponding buttons are defined by the evaluation method. Quantitative and qualitative evaluations have different fields and buttons.
- I Blank values will be subtracted in the readout.

- I The mean value of replicates will be calculated
- I Once the conditions/parameters of a given experiment have been set, these settings may be saved as a protocol. All parameters, such as wavelength and plate layout, will be saved.
- I Wells without values (concentration or sample ID) are shown with a ring instead of solid colour.

Quantitative Evaluation

When the quantitative evaluation is selected, the window will be as shown in figure 5.

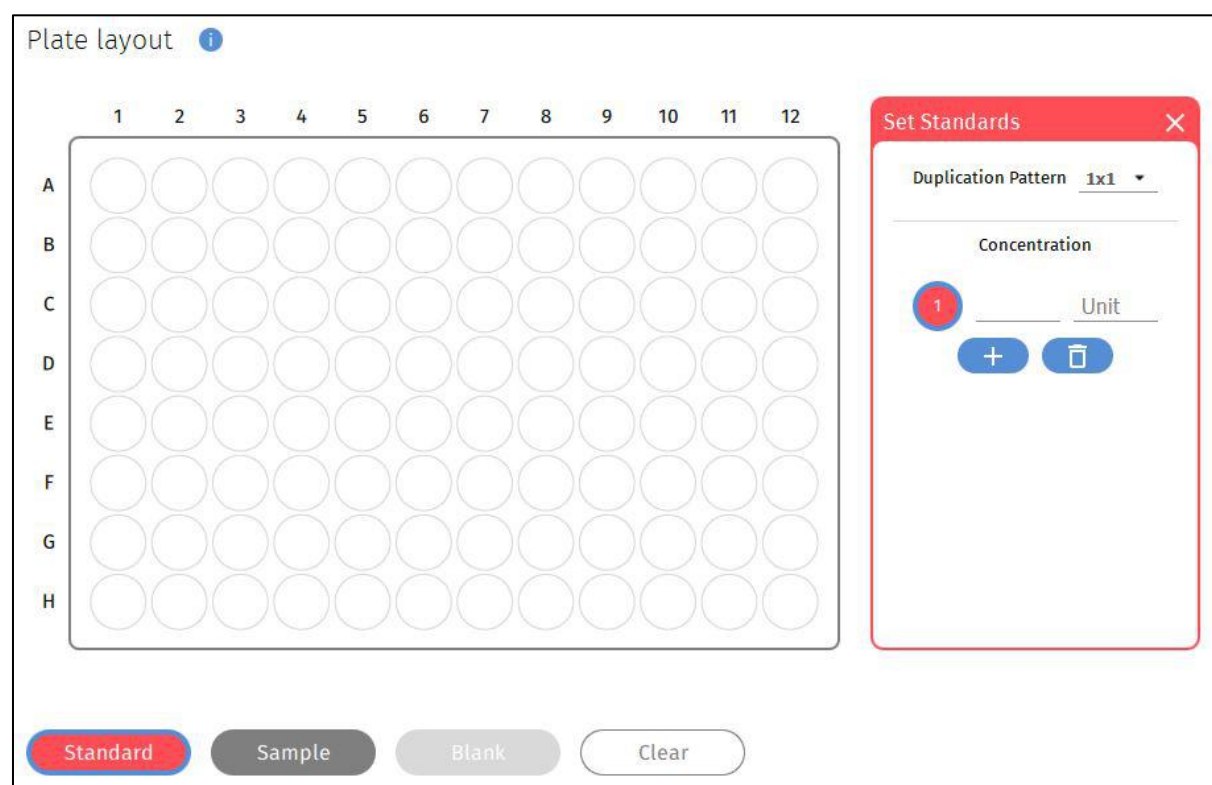

Figure 4. Quantitative plate definition window.

To define a well, click on the desired button below the plate. You may then click and drag, or individually define single wells. The blue ring indicates which field is currently selected; all fields will be defined starting with the selected number.

To enter a concentration or sample ID, type the value in beside the number and press ENTER to move to the next field.

To enter a unit, enter the desired unit in the first field and press ENTER, or choose a predefined unit from the drop-down menu. All fields will be automatically filled out according to the first selection.

To define, for example, two duplicate standard rows, click and drag the desired number of wells, release, then click and drag again in the next row.

To set a blank or to empty a given well, click on the “Blank” or “Empty” button respectively, then click the desired well or drag and drop across the plate.

- I When blank wells are selected, the values of these wells will be subtracted in the readout.

Qualitative Evaluation

Upon selection of qualitative evaluation, the plate layout window will look like that shown in figure 6. Define the plate according to the description above.

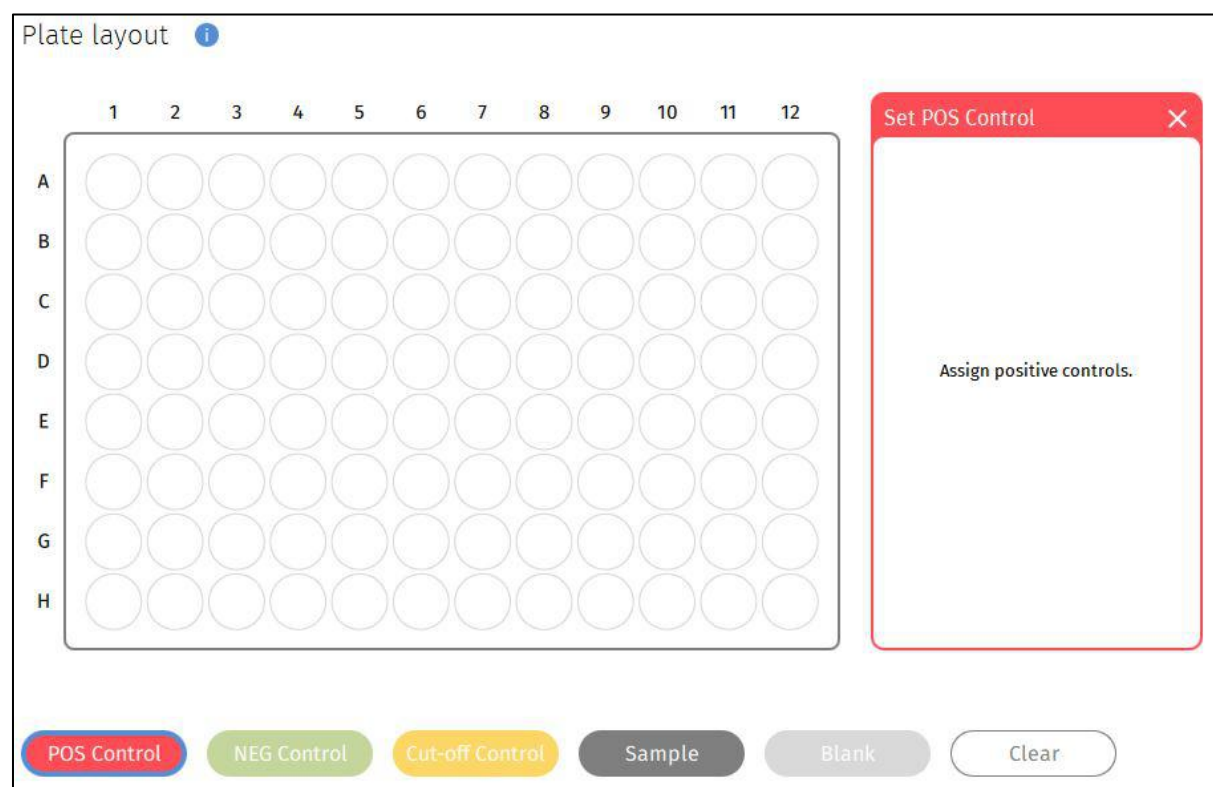

Figure 5. Qualitative plate definition window.

Use Predefined Standard Curve

In a quantitative assay, a predefined or previously measured standard curve can be used to determine the concentrations of a new set of samples with identical experiment parameters. After selecting the checkbox “Use Predefined Standard Curve”, you may enter the curve parameters manually or load a standard curve from a previous assay.

After selecting the checkbox “Use predefined Standard curve”, you cannot assign any new standards.

- ! In a quantitative assay, the standard curve is a function of various assay parameters, such as the temperature, timing, or age of the assay kit. Before using this feature, it is advisable to validate your assay for compatibility.
- I As the above-mentioned experiment conditions are subject to change, it is recommended to use a new standard curve when performing a new assay.

File Types

The following file types are used by the Absorbance 96 App:

Table 1. File Types in the Absorbance 96 App

Quality	Extension
Protocol	.byop
Assay	.byoa
Export	.csv/.pdf

4.3 Running the assay

Procedure walkthrough

1. Empty Slot

Ensure the slot is empty for the next step.

2. Initialization

Click “OK” to start the initialization. The initialization is carried out, which is indicated by a short illumination of the respective LEDs.

I The slot must be empty for initialization.

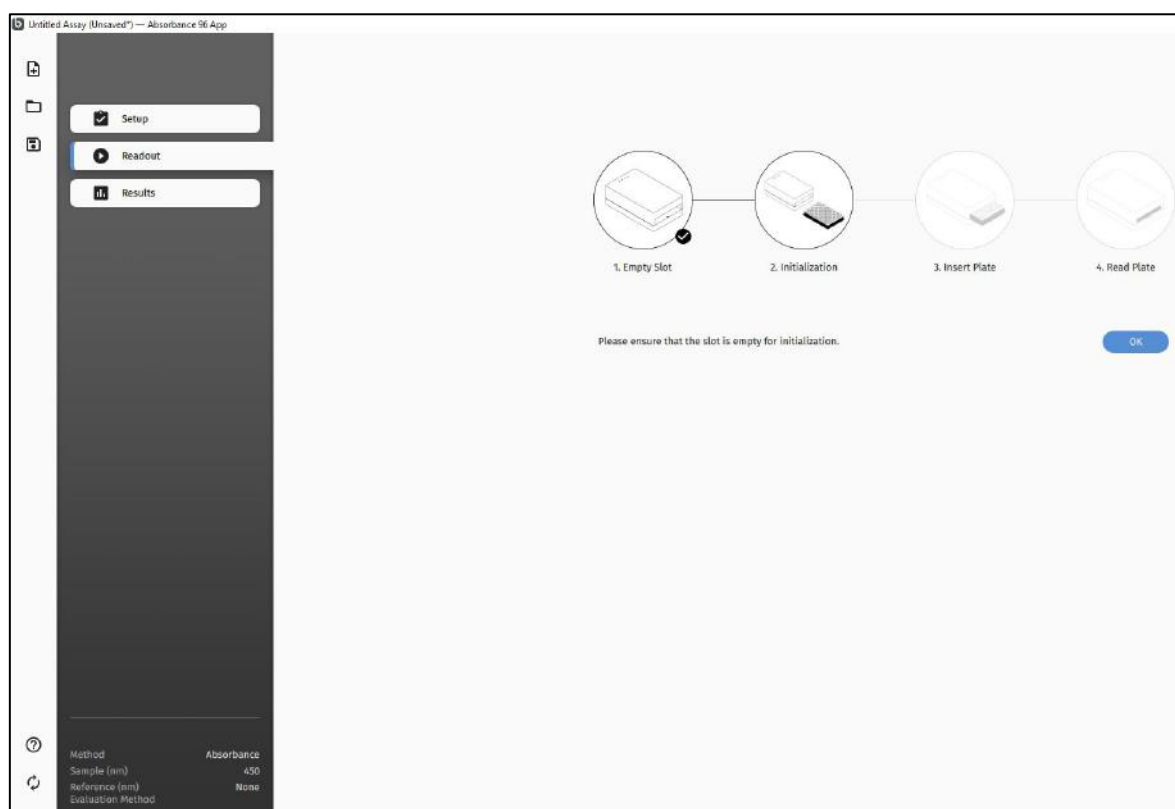

Figure 6. Prompt, guidance through the measurement steps.

3. Insert Plate

After successful initialization, you will be prompted to insert the microtiter plate. Pay attention to the alignment of the microtiter plate. For orientation, a pictogram on the top of the Absorbance 96 indicates the correct alignment of the microtiter plate. (The pictogram is a schematic representation. The actual shape of the microtiter plate, especially the position of the rounded corner, may vary and differ from the illustration. Base your alignment on the A1 Well).

After insertion, confirm in the software that the microtiter plate has been inserted by clicking OK. The measurement will subsequently be carried out, accompanied by a short illumination of the respective signal lights.

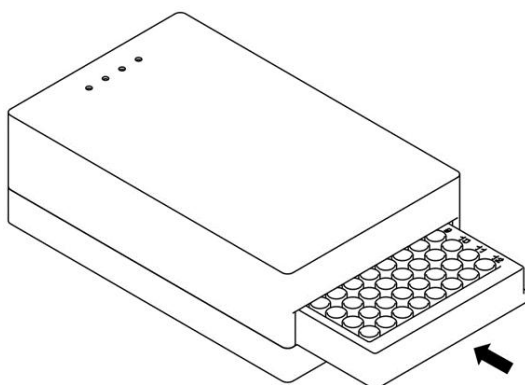

Figure 7. Insertion of the microtiter plate.

In order to guarantee a correct measurement result, please pay attention to the following warnings:

- !! When inserting the microtiter plate, pay attention to its alignment.
- !! Make sure that the microtiter plate was inserted in the slot completely. In that case the arrow at the bottom of the slot is visible completely.
- !! The bottom of the microtiter plate must be dry before it is inserted into the instrument. If the microtiter plate is wet at the bottom, dry it with a paper towel or similar.
- !! Shocks of the Absorbance 96 and of the microtiter plate can cause an unwanted signal. Therefore, neither the Absorbance 96 nor the microtiter plate should be touched during measurement.
- !! Note that the system depends on a clean and dust-free environment. Therefore, do not wear powdered safety gloves.
- !! Ensure that no direct sunlight or other strong light sources shine on the Absorbance 96 and especially into its slot.
- !! Insert the plate cautiously to avoid spills

3. Read Plate

When the measurement is complete, the results will be shown.

You may now remove the microtiter plate from the Absorbance 96. To do this, push the eject button on the rear side of the device.

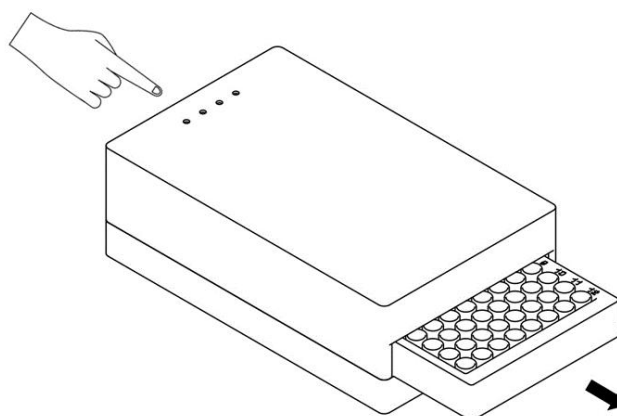

Figure 8. Remove the microtiter plate.

Results and Interpretation

Plate Overview: Provides an overview of the different OD values in their respective wells. Undefined wells are not shown. Click on a given well to see the OD, label and, if applicable, concentration.

Graph Overview: A representation of the data will be shown on the graph. The curve will be dependent on the data analysis method chosen and will be fitted accordingly. By choosing the right regression method, the distance from the curve to each point is minimized. Using the standard curve, the concentration of each sample is calculated. The equation below the graph reflects the regression method applied and offers further data.

Tabular View: Provides an overview of the various samples, wells, ODs and calculations.

Table 2. Overview of terms, results section

Parameter	Description
ID	The assigned ID of a given standard
Well	The assigned well
Absorbance	The absorbance reading in OD units
Concentration CV	The coefficient of variation between replicates
Standard conc.	The entered concentration values for the standards
Concentration	The calculated concentration values

Mean Absorbance

The mean absorbance of replicate wells

Result*

Pos/Neg/Intermediate result of a qualitative experiment

(*Only appears by qualitative evaluation)

5 Information required by the user

5.1 Explanation of the signal lights

Table 3. Explanation of the signal lights

Activity of the signal light	Meaning
All signal lights flash simultaneously	Error, software shows error message
No signal lights light up	Device is off Device is waiting for input Device is defective
All signal lights light up briefly in sequence	Self-test after connection to power
Signal light of the respective measuring channel flashes/illuminates continuously	Initialization/measurement in progress

5.2 Notes on troubleshooting

If there is an error, all four signal lights flash simultaneously. In this case, check the software to see which error is present.

In the event of the following errors, a new measurement can be carried out immediately after the error has been corrected.

Table 4. Error messages and solutions

Type of error	Cause	Solution	Restart necessary?
Initialization failed	There was a microtiter plate in the slot during initialization.	Remove the plate/all objects	No
	The inside of the slot is dirty	Clean the inside of the slot according to the cleaning instructions in chapter 6.2.	No
Interference due to ambient light that is too bright	Too much ambient light is entering the slot	Make sure the instrument is not exposed to too much ambient light, e.g. direct sunlight, during the measurement process.	No
Temperature out of specification	The ambient temperature was too high or too low	Make sure the ambient temperature is between 5-45°C	No
USB Power Supply Defective (<450mA or < 4V)	Defective USB port	Use a different USB port on the computer or a different computer	Yes. Remove cable and reconnect it.

	Using a USB hub	connect the instrument directly to the computer or use another USB hub.	
	Defective micro-USB cable	contact service personnel	
Irrecoverable hardware error*	Irrecoverable hardware error	Contact service personnel.	N/A

*If the following error occurs, the user cannot correct the error

6 Maintenance and cleaning

6.1 Maintenance

The Absorbance 96 is maintenance-free. Each time the instrument is switched on, an internal self-test is carried out to ensure there are no malfunctions.

There are no parts within the ABSORBANCE 96 that can be serviced by the customer. It is only necessary to ensure that the device is kept clean.

The accuracy of the device can be checked with a reference plate. If you check more than one point for accuracy, you can also confirm the linearity of the reader. Byonoy recommends the reference plate from Hellma GmbH (item code 666-R013), for which the following steps are described:

- 1) Measure the plate at the desired wavelength. Ensure that there is no dust or other contamination on the reference plate.
- 2) Compare results taking the measurement uncertainty and specifications of the reader into account and use the following formula: $OD_{RP} - MU - SP \leq OD_{RES} \leq OD_{RP} + MU + SP$

OD_{RP} : Optical density of the reference plate at the desired wavelength. This value is found on the calibration certificate from the manufacturer.

MU : Measurement uncertainty of the reference plate. This value is found on the calibration certificate from the manufacturer.

SP : Accuracy specification of the reader at measured optical density. This value is found in chapter 7.

OD_{RES} : The optical density measured by the reader at the desired wavelength.

Example:

OD_{RP} : 1.554

MU : ± 0.0079

SP : $0.000-2.000 OD \leq (1\% + 0.010 OD)$

OD_{RES} : 1.573

(1) $1.554 - 0.0079 - (1.554 * 0.001 + 0.010) \leq OD_{RES} \leq 1.554 + 0.0079 + (1.554 * 0.001 + 0.010)$

(2) $1.52056 \leq OD_{RES} \leq 1.58744$

The measured Optical Density of the reader lies within the calculated range and hence the accuracy of the reader is verified.

- 3) Rotate Reference plate by 180 degree and repeat steps 1 and 2.
- 4) If all Results (OD_{RES}) are within the range, the accuracy and linearity of the device have been verified.

In case that the results are outside the range, please contact the technical service or the local responsible person.

- I Please follow the plate manufacturer's recalibration instructions for the reference plate.

6.2 Cleaning

Remove the Micro-USB cable from the instrument before cleaning.

- !! Make sure before cleaning, that there is no microtiter plate in the instrument.

Cleaning the housing

The surfaces of the housing should be cleaned regularly. For this purpose, you can use e.g. a cloth, or a sponge lightly wetted in water. For heavier soiling, clean the surface of the housing with a mild soap solution diluted with water or glass cleaner and then wipe with a lightly moistened cloth or sponge to remove any residue. Do not use scouring agents.

Cleaning the slot

To clean the slot of the RIDA ABSORBANCE 96, first open the four screws on the bottom of the instrument (see Figure 11) using the Hex key provided.

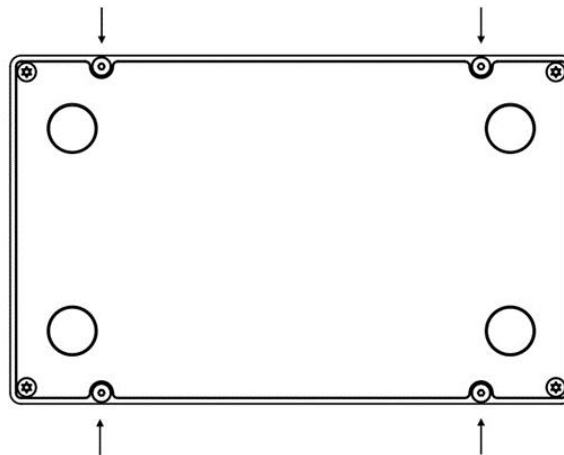

Figure 9. Bottom side of the instrument

- I Do not loosen any screws that are not explicitly marked in the manual, as this can lead to a malfunction and may void the instrument's warranty.

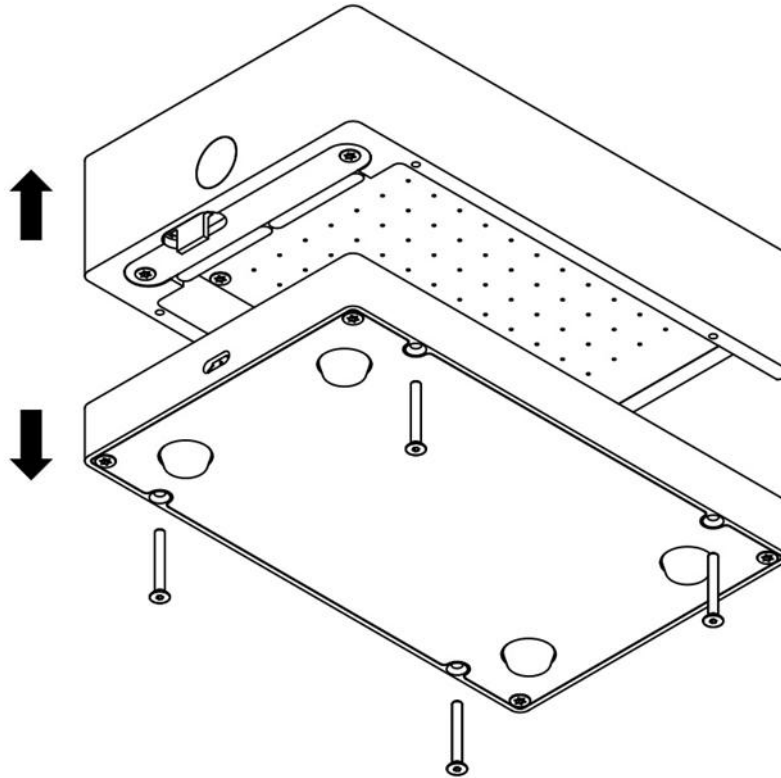

Figure 10. Pull the instrument apart into its two components

Carefully pull apart the top and the bottom of the instrument to unplug the plug connection on the back of the instrument.

- I To avoid damaging the rigid plug connection between the top and bottom of the instrument, grasp the instrument at the back during the pull movement. **Avoid any tilting movement.**

Use a dry microfiber cloth or a bellows to carefully remove dust or dirt from the surface. If this is not enough, the microfiber cloth can be slightly soaked with 80% ethanol to carefully remove dust or contamination from the surface.

Do not allow water or other liquids to get inside the instrument. If this happens, return the device to the manufacturer for inspection.

Warnings for cleaning

When cleaning, pay attention to the following warnings. The non-observance of these warnings may result in damage to the user or to the instrument. This can lead to a reduction of the service life or in measurement errors:

- !! Always avoid spraying liquid directly onto the surfaces of the ABSORBANCE 96. This is especially important for the inside of the slot, where there are optical elements that are very sensitive and essential for the functioning of the instrument.
- !! Never clean the inside of the slot with sharp, abrasive, solvent-containing agents.
- !! Biological hazard: Always wear gloves during cleaning operations that may be associated with contact with biological or generally hazardous materials or liquids.

6.3 Technical support

In case of problems with the instrument, please contact the technical service or the local responsible person.

!! Biological hazard: It is your responsibility to decontaminate the instrument and all accessories before servicing and before returning the instrument or accessories to the manufacturer.

For decontamination of the Absorbance 96, follow the government guidelines for inactivation of organisms used in biological laboratories.

6.4 Repairs

Repairs on the device may only be carried out by the manufacturer. Please contact the service department. The product liability expires if the device is modified by unauthorized persons and by the installation of parts of a different type.

7 Performance data and technical data

Table 5. Performance & technical data

Parameter	Value
Type of product	Absorbance reader
Product name	Absorbance 96
Service life	10 years at an average use of 4h/day
Housing material	Aluminium
Place for use	Laboratory
Degree of contamination	2
Temperature for storage/measurement	5-40°C
Temperature (Transport)	-10-50°C
Relative tolerated humidity (storage/measurement)	0-70%
Air pressure (measurement)	900-1070 hPa
Air pressure (storage/transport)	600-1070 hPa
Elevation	Max 5100m
Measurement method	Absorbance
Measuring technique	Endpoint and Kinetic
Microplate types	96-well, fat shaped bottom
Light source	4 LEDs
Filters	4
Detection	96 Photodiodes
Measurement range	0-4.0 OD
Resolution	0.001 OD
Accuracy*	405 nm: 0,000–2,000 OD \leq (1,5 % + 0,010 OD) 2,000–3,000 OD \leq (3 % + 0,010 OD) \geq 450 nm: 0,000–2,000 OD \leq (1 % + 0,010 OD) 2,000–3,000 OD \leq (1,5 % + 0,010 OD)
Reproducibility**	0,000–2,000 OD \leq (0,5 % + 0,005 OD) 0,000–3,000 OD \leq (1 % + 0,005 OD)
Linearity***	405 nm: 0,000–2,000 OD \leq 1,5 % 2,000–3,000 OD \leq 3 % \geq 450 nm: 0,000–2,000 OD \leq 1 % 2,000–3,000 OD \leq 1,5 %

Connection to computer	USB 2/USB 3 with 5 VDC and max. 3A
Dimensions	55 x 96 x 154 mm
Power supply	5 VDC
Nominal value/Characteristic of the fuse	1A/very fast-acting
Power input	2.5W
Weight	900g

*Accuracy is the maximum deviation between the determined value and the true value.

**Reproducibility is the maximum deviation between the determined values when the measurement is repeated directly.

***Linearity is the maximum deviation between the true and the determined increase of the value.

8 Guarantee

The warranty period of the Absorbance 96 is 24 months. If a defect occurs in your device during the warranty period, please contact our service staff directly. The instrument may only be operated in technically perfect condition.

In the event of defects that could endanger employees or third parties, the device may only be used again after it has been repaired. This warranty does not cover damage caused by improper use or external mechanical influences, transport damage or unauthorized intervention in the device by unauthorized persons.

EG-Konformitätserklärung
EC-Conformity Declaration



Byonoy GmbH – Bernstorffstraße 118 - 22767 Hamburg - Germany

Das bezeichnete Produkt entspricht den einschlägigen grundlegenden Anforderungen der aufgeführten EG-Richtlinien und Normen. Bei einer nicht mit uns abgestimmten Änderung des Produktes oder einer nicht bestimmungsgemäßen Anwendung verliert diese Erklärung ihre Gültigkeit.

The Product named below fulfills the relevant fundamental requirements of the EC directives and standards listed. In the case of unauthorized modifications to the product or an unintended use this declaration becomes invalid.

Produkttyp
Product type

Absorptionsmessgerät

Typenbezeichnung
Type designation

Absorbance 96

Einschlägige EG-Richtlinien/Normen
Relevant EC directives/standards

2011/65/EU; 2014/30/EU;

DIN EN ISO 14971:2013-04; DIN EN 62366-1:2017-07; DIN EN 62304:2016-10; DIN EN 61010-1:2011-07; DIN EN 61010-2-101:2017-10; DIN EN 61326-1:2013-07; DIN EN 61326-2-6:2013-07

Hamburg, den 08.08.2019



Dr. Sebastian Metz



Dr. Yousef Nazirizadeh