

The logo for Revvity, featuring the word "revvity" in a white, lowercase, sans-serif font on a black background. The logo is positioned in the upper right corner of the page, partially overlapping a decorative graphic of overlapping, translucent yellow and green spheres.

revvity

USER MANUAL

Mixer and Macro Homogenizers

Version: K Date: October 2024
Document Number: 17258

Data herein has been verified and validated. It is believed adequate for the intended use of the instrument. If the instrument or procedures are used for purposes over and above the capabilities specified herein, confirmation of the validity and suitability should be obtained; otherwise Revvity does not guarantee results and assumes no obligation or liability. This publication is not a license to operate under, or a recommendation to infringe upon, any process patents.

This product is warranted to be free from defects in material and workmanship for a period of ONE YEAR from the date of delivery. Revvity will repair or replace and return free of charge any part which is returned to its factory within said period, transportation prepaid by user, and which is found upon inspection to have been defective in materials or workmanship. This warranty does not include normal wear from use; it does not apply to any instrument or parts which have been altered by anyone other than an employee of Revvity nor to any instrument which has been damaged through accident, negligence, failure to follow operating instructions, the use of electric currents or circuits other than those specified on the plate affixed to the instrument, misuse, or abuse. Revvity reserves the right to change, alter, modify, or improve any of its instruments without any obligation whatever to make corresponding changes to any instrument previously sold or shipped.

THE FORGOING OBLIGATION IS IN LIEU OF ALL OBLIGATIONS AND LIABILITIES INCLUDING NEGLIGENCE AND ALL WARRANTIES OF MERCHANTABILITY OR OTHERWISE, EXPRESSED OR IMPLIED IN FACT OR BY LAW, AND STATE OUR ENTIRE AND EXCLUSIVE LIABILITY AND BUYERS EXCLUSIVE REMEDY FOR ANY CLAIM OF DAMAGES IN CONNECTION WITH THE SALE OR FURNISHING OF GOODS OR PARTS, THEIR DESIGN, SUITABILITY FOR USE, INSTALLATION, OR OPERATION. REVVITY WILL IN NO EVENT BE LIABLE FOR ANY SPECIAL OR CONSEQUENTIAL DAMAGES WHATSOEVER, AND THEIR LIABILITY UNDER NO CIRCUMSTANCES WILL EXCEED THE CONTRACT PRICE FOR THE GOODS FOR WHICH LIABILITY IS CLAIMED.

This product has been engineered for safety; however, basic safety precautions and common sense must always be demonstrated when using any electrical product.

- Use this product only for its intended purpose.
- Keep this product away from heated surfaces.
- **DO NOT** attempt to modify any part of this product.
- **DO NOT** allow the machine to be submerged in any liquid.
- **DO NOT** use in any setting other than an indoor laboratory.
- **DO NOT** use attachments not recommended by the manufacturer.
- **DO NOT** operate the product if it is damaged in any way.
- **DO NOT** operate the product with the safety ground disconnected.
- **DO NOT** modify the plug or cord that is provided.

WARNING: Reduce the risk of unintentional starting; make sure the machine is OFF before plugging into a power supply.

WARNING: Damaged or worn power cords should be repaired or replaced immediately by a qualified electrician.

WARNING: Improper connection of the equipment can result in a risk of electric shock.

Copyright

This manual is published by Revvity 935 Cobb Place Blvd, Kennesaw, GA 30144 USA. Copyright Revvity, Inc. All rights reserved, including but not limited to those rights to reproduce this publication or parts thereof. Reproduction of this publication or parts thereof, or the products it describes, by any means or in any form is expressly prohibited without the written permission of Revvity.

Trademarks

Revvity is a registered trademark of Revvity. All other trademarks are the property of their respective owners.

Proper Equipment Operation

To reduce the risk of electric shock, do not remove the cover. No user serviceable parts are inside. Refer to qualified service personnel if help is required. Use this product only in the manner described in this manual. If the equipment is used in a manner not specified by the manufacturer, the protection provided by the equipment may be impaired.

FCC

This device complies with part 15 of the FCC (United States Federal Communications Commission) Rules. Operation is subject to the following two conditions:

- This device may not cause harmful interference
- This device must accept any interference received, including interference that may cause undesired operation.

CE/UKCA











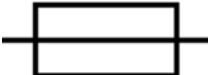

This device complies with all CE and UKCA rules and requirements.

Changes or modifications to this equipment not expressly approved by the party responsible for compliance could void the user's authority to operate the equipment.

Table of Contents

Table of Symbols.....	5
Specifications - Mixer.....	6
Specifications - Macro.....	6
Site Requirements.....	6
Assembly.....	8
General Operation.....	9
Generator Probe Installation.....	9
Generator Probe Compatibility.....	10
Quick Connect Coupling Assembly.....	10
Determining Motor Speed.....	10
Sealed Chamber Assemblies.....	11
Using Blade Chamber Assemblies.....	11
Sealed Generator Probe Assemblies.....	12
Installing Sealed Chamber Assemblies.....	12
Cooling a Vessel.....	13
Decontamination.....	13
Maintenance.....	14
Motor Brush Maintenance.....	14
Removal of Aluminum Coupling.....	14
Bearings and Lubrication.....	14
Grounding Instructions.....	14
Troubleshooting.....	15
Appendix.....	15

Table of Symbols

Symbol	Description	Symbol	Description
	Caution. Refer to the User documentation (ISO 7000-0434B)		On (power). (IEC 60417-5007)
	Hazardous voltage; risk of electric shock. (IEC 60417-6042)		Off (power). (IEC 60417-5008)
	Fuse. (IEC 60417-5016)		Consult Instructions for Use. (ISO 7000-1641)
	Alternating current. (IEC 60417-5032)		CE Compliance Mark
	UKCA Certification Mark		WEEE symbol (EN50419:2005)
	RoHS Certification Mark		KC Certification Mark

Specifications - Mixer

Part Number	17105 (115V) 17106 (220V)
Input Voltage	17105 - 100-115V, 50/60 Hz and 17106 - 200-230V, 50/60 Hz
Weight	20.9 lbs. (9.5kg)
Dimensions	W: 9.8" (25cm), H: 24" (61 cm)
Power	600 Watts
Sample Volume	0.25 mL to 10 L
Speed	500 - 18,000 rpm
Standards Approval	CE and UKCA Approved

Specifications - Macro

Part Number	17505 (115V) 17506 (220V)
Input Voltage	17505 - 100-115V, 50/60 Hz and 17506 - 200-230V, 50/60 Hz
Weight	20.9 lbs. (9.5kg)
Dimensions	W: 9.8" (25cm), H: 24" (61 cm)
Power	1800 Watts
Sample Volume	0.25 mL to 30 L
Speed	1,000 - 20,000 rpm
Standards Approval	CE and UKCA Approved

Site Requirements

Operating Environment

4°C to 40°C / 39°F to 104°F, Humidity: 5% to 95% RH

Ambient Air

The system must be located in an area where the ambient air is clean. No emission of solid particles or smoke in the air by adjacent equipment is allowed. The level of dust should be comparable to that of normal laboratory spaces.

External Fire Protection

External fire protection should be installed according to local regulations for equipment operating unattended.

The Mixer and Macro Homogenizers consists of the following:

Description	Part Number Mixer	Part Number Macro	Qty
Motor Drive Unit	17105 (115V) 17106 (220V)	17505 (115V) 17506 (220V)	1
Clamping Knob Assembly	17164	17164	1
Generator Probe Adapter	15001	15001	1
Finished Base Assembly	17234	17234	1
Support Post	17026	17026	1
Tool Kit	17104	17104	1
Instruction Manual	17258	17258	1

The following components are supplied as part of the Tool Kit (P/N 17104):

Description	Part Number	Qty
Gen Probe Multi-Tool	00-402	2
20, 30, 45, 55 mm Knife Tool	15100K	1
1/16" Allen Wrench	00-416	1
5/64" Allen Wrench	60027	1
3/32" Allen Wrench	60128	1
1/8" Allen Wrench	60241	1
5/32" Allen Wrench	737	1
5/16" x 5/8" Combo Wrench	60033	1
5 mm Lower Bearing Press	59105	1
7 mm Lower Bearing Press	59107	1
Lubricant	61971	1
Pin Wrench for 15001	00-404	1

Assembly

Use the following instructions to assemble the Mixer and Macro units

1. Insert the support post into the support base. Secure the set screw through the back of the support base into the groove in the support post, using 1/8 in. Allen (P/N 60241) provided.
2. Place the clamping knob assembly in the motor support housing with the two flat surfaces on the clamping mechanism facing the support post hole. The clamping knob assembly may be used either on the left or the right side of the Mixer or Macro.
3. Slide the motor support housing onto the support post and clamp it into place with the clamping knob assembly. The motor support housing should be positioned over the two longer legs of the support base.

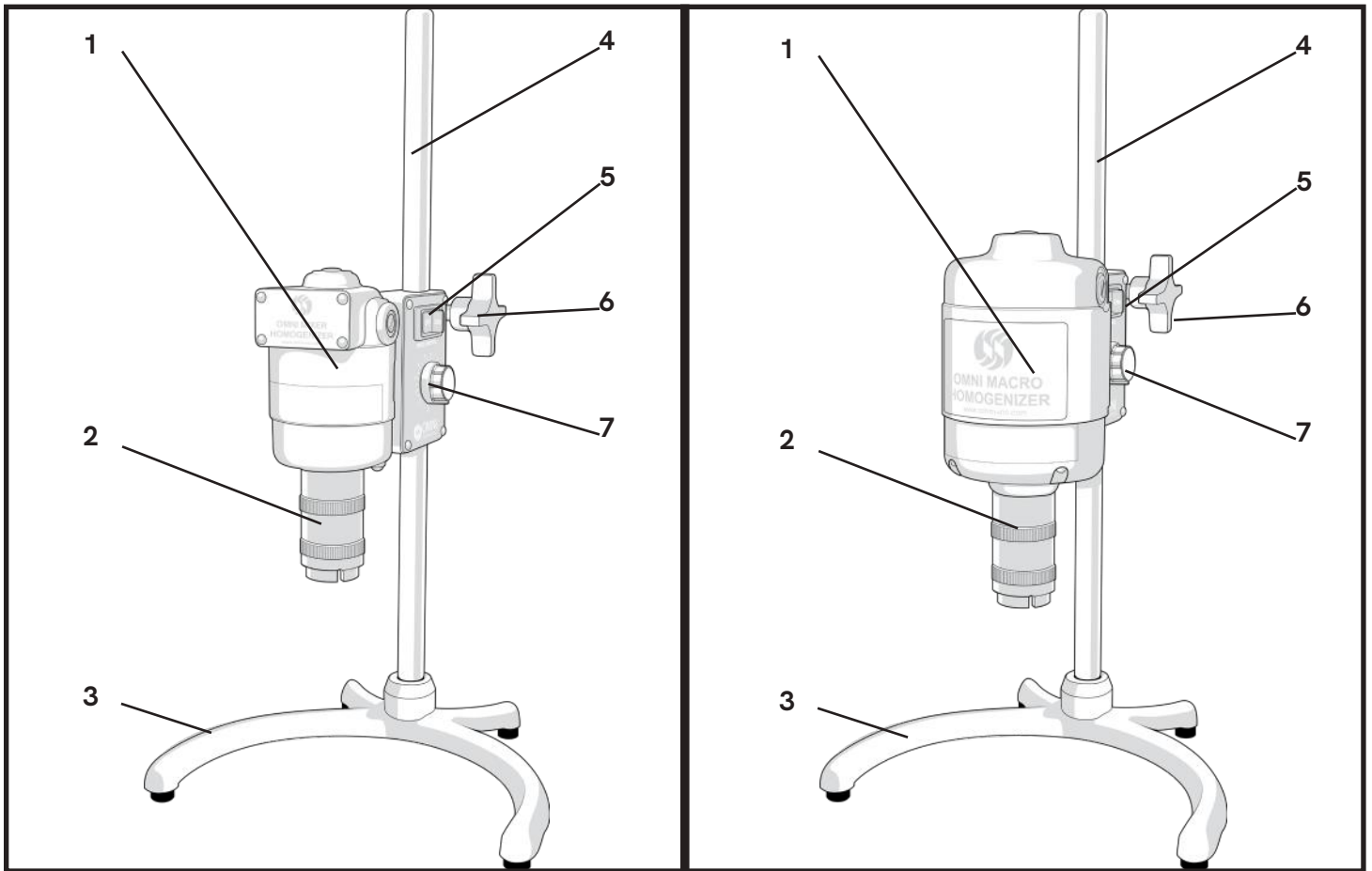

1. Motor Drive Unit
2. Coupling Adapter
3. Motor Support Base
4. Motor Support Post
5. On/Off Switch
6. Motor Support Knob

7. Speed Selector Knob

WARNING: When using sealed chamber assemblies, the bottom of the chamber assembly must rest on the movable platform. This prevents the chamber assembly from disengaging from the motor, which could expose rotating blades, and could lead to a broken seal.

CAUTION: To prevent damage to the drive mechanism, never operate the motor without a sealed chamber assembly or generator probe installed.

NOTE: If you experience excessive vibration, heat, or bearing wear, please contact technical support.

General Operation

The speed of the Mixer or Macro may be regulated to achieve optimum results when working with different materials. A speed selection knob is located at the side of the unit, as is a separate "OFF" or "ON" switch. When in the "ON" position the motor speed can be varied from 0 rpm to maximum speed. Select the optimal speed for each different combination of sample and accessory for best processing results.

Generator probes can be used in open containers or in sealed chamber assemblies. Sample processing efficiency is effected by:

- Amount of material processed vs. size and speed of the generator probe.
- Container geometry and size (round vessels encourage swirling, while fluted or cornered vessels disrupt flow patterns for more effective mixing/processing).
- Processing speed vs. optimal speed.
- Size and type of material and flow characteristics (material particles must be small enough to be carried into the generator head for optimal processing).

To operate the generator probe simply remove the blue protective cap from the end of the generator probe. Keep the blue protective cap on the tip of the generator probe when the generator probe is not being used.

NOTE: When using PTFE lower bearings, immerse the bottom of the generator probe in liquid or in the sample to avoid premature failure of the lower bearing.

NOTE: Liquid circulates through the two holes in the generator probe. DO NOT block the upper hole, although the lower hole may be completely submerged during processing.

NOTE: For optimal sample recovery during processing, completely remove the generator probe from the sample prior to turning off the motor drive unit.

Generator Probe Installation

All generator probes (sold separately) are easily installed to the motor unit by following these steps:

1. Screw the generator probe adapter (P/N 15001) into the coupling adapter
2. Screw the generator probe into the generator probe adapter until the O-ring is completely inside the generator probe adapter.
3. If the generator probe does not thread fully into the generator probe adapter, then unscrew the generator probe from the generator probe adapter. Slightly rotate the rotor shaft collar on the generator probe. Then return to step 2.
4. Tighten the generator probe by hand with moderate force.
5. Remove the blue protective cap from the tip of the generator probe and the homogenizer is ready to operate.

NOTE: The tip of the generator probe, especially on the saw tooth generator probes, is sharp. For safety purposes it is advisable that the protective cap be replaced on the generator probe when not in use.

NOTE: The bottom of the generator probe is extremely fragile and care should be taken to protect it. Replace the blue protective cap on the end of the generator probe when the generator probe is not being used.

WARNING: Never operate the motor with the generator probe (or sealed chamber assembly) partially threaded onto the motor. To prevent damage to the motor and attachments be sure that the generator probe (or sealed chamber assembly) is fully threaded into the coupling adapter. Failure to do so will result in damage to the coupling system.

WARNING: Always submerge probe in liquid before starting. Never run dry.

Generator Probe Compatibility

Diameter	Length	Processing Range	Type	Particle Size	Part Number
10 mm	95 mm	1.5 mL - 100 mL	Saw Tooth	Fine	15051
			Saw Tooth	Fine	150510
20 mm	195 mm	50 mL - 2 L	Saw Tooth	Fine	15201
	100 mm			Coarse	15201W
			Saw Tooth	Fine	15401
				Coarse	15401W
			145 mm	Saw Tooth	Fine
	195 mm		Coarse		15020W
30 mm	195 mm	75 mL - 10 L	Flat Bottom	Fine	150-30NA-195
			Flat Bottom Wide Window	Coarse	150-30WA-195
45 mm Macro only	195 mm	200 mL - 25 L	Flat Bottom	Fine	150-45NA-195
55 mm Macro only	195 mm	300 mL - 30 L	Flat Bottom	Fine	150-55NA-195

Quick Connect Coupling Assembly

The Quick Connect Coupling Assembly is an optional accessory.

To use, attach a Quick Connect Adapter to your chamber assembly or generator probe.

Next, slide the Adapter into the Quick Connect Coupling and a retaining ring positions into place for a secure hold. To disconnect, simply slide the ring upward and the processing accessory is conveniently released.

17210 Quick Connect
Coupling Assembly



17204 Quick Connect
Adapter

Determining Motor Speed

To determine motor speed during operation, a tachometer (not included) may be inserted into the Mixer or Macro through the top of the motor removing the protective snap cap.

Sealed Chamber Assemblies

Sealed chamber assemblies are available as separately ordered items for use with the Mixer or Macro. They consist of chambers, many of which are fluted to facilitate mixing by inhibiting swirling, gasket screw on cover seals to inhibit aerosol release, a shaft assembly, and a sharpened stainless steel blade, or generator probe. Chamber materials include stainless steel, glass, polycarbonate, and polypropylene. A full range of titanium chamber assemblies is also available for applications requiring protection from leached elemental components, or where additional strength is a factor.



Using Blade Chamber Assemblies

Stainless Steel or Titanium - These chamber assemblies are intended for liquid and semi-solid materials. Homogenization and mixing will normally be completed within 30 seconds to one minute. For processing solid materials, first reduce particle size diameter to 1cm or less. Load the material to be processed in the chamber. Do not fill the chamber to full capacity. Processing of too much volume could force liquid up through the rotor shaft.

Glass and Plastic - These chamber assemblies are intended primarily for low-viscosity liquids or for light duty homogenization at speeds below 5,000 rpm. At speeds greater than 5,000 rpm, place glass jar into a secondary container for added protection.

WARNING: The maximum recommended speed when using any of the blade chamber assemblies is 10,000 rpm. Speeds in excess of 10,000 rpm can cause excessive bearing wear or part failure.

WARNING: Inspect glass or plastic chambers for any scratches or cracks, and do not use if any are found. Eye protection and utilization of a secondary container is recommended to prevent damage or injury in case of glass breakage.

Centrifugable - These assemblies are available in plastic or stainless steel, and should be used in the same manner as described for glass, plastic, and stainless steel above.

Breaking Down Specimen Particles - At speeds below 5,000 rpm, specimen particles may be broken down in the by using hard materials, such as glass beads. The system will act as a "bead mill", agitating the chamber while the hard materials do the work. Since sharpness is not essential, a dull blade should be used.

Homogenizing - For more complete homogenization of some materials, it may be helpful to rock the motor drive unit slightly during processing in order to churn up the specimen within the chamber.

WARNING: It is recommended that "bead mill" processing should not be undertaken in a glass vessel.

Adding a Grinding Medium - To attain the desired effect (cell breakdown) a combination of procedures may be useful. First homogenize the specimen in solution at maximum recommended speed (10,000 rpm) with a sharp knife blade. Then change to a dull knife blade, add a grinding medium and run the homogenizer at 5,000 rpm for ten to fifteen minutes.

Using Generator Probes - To facilitate homogenization of some materials, it may be useful to pre-process the sample by using one of the techniques described above, and then completing the process by using a generator probe. Generator probes can achieve particle size reduction to less than 2 microns.

WARNING: When processing pathogenic material in a sealed container, carefully check seals and connections to be certain that they are not worn or leaking. A fume hood is recommended for processing pathogens, even with a sealed container.

WARNING: Knife blades are sharp. Handle carefully to avoid injury. **WARNING:** Knife blades are sharp. Handle carefully to avoid injury.

CAUTION: To prevent damage to the drive mechanism, *never* operate the motor without a sealed chamber assembly or generator probe installed.

CAUTION: Never operate the motor with the generator probe (or sealed chamber assembly) partially attached to the Quick Connect Adapter.

NOTE: If you experience excessive vibration, heat, or bearing wear, please contact Revvity.

Sealed Generator Probe Assemblies

Sealed chamber generator probe assemblies are available for use with the Mixer and Macro but are not supplied with the instrument. They consist of chambers, many of which are fluted to facilitate mixing by inhibiting swirling, gasket screw on cover seals to inhibit aerosol release, and a generator assembly. Chamber materials include stainless steel, glass, polycarbonate, and polypropylene. A full range of titanium chamber assemblies is also available for applications requiring protection from leached elemental components, or where additional strength is a factor.

Installing Sealed Chamber Assemblies

All chamber assemblies are easily installed to the motor unit by following these steps:

1. Attach the chamber (with adapter if required) to the cover/generator probe assembly. Method of attachment is a left-handed screw thread. Tighten the assembly securely.
2. Attach the chamber assembly to the motor by screwing the chamber cover into the coupling adapter.
3. If the chamber assembly does not thread fully into the coupling adapter, then unscrew the chamber assembly from the coupling adapter. Slightly rotate the rotor shaft collar on the generator probe. Then return to Step 2.
4. Before operating, make sure that the chamber assembly rests securely on the tabletop.

CAUTION: For safe operation, all sealed chamber assemblies attached to the Mixer or Macro must be lowered to the table surface.

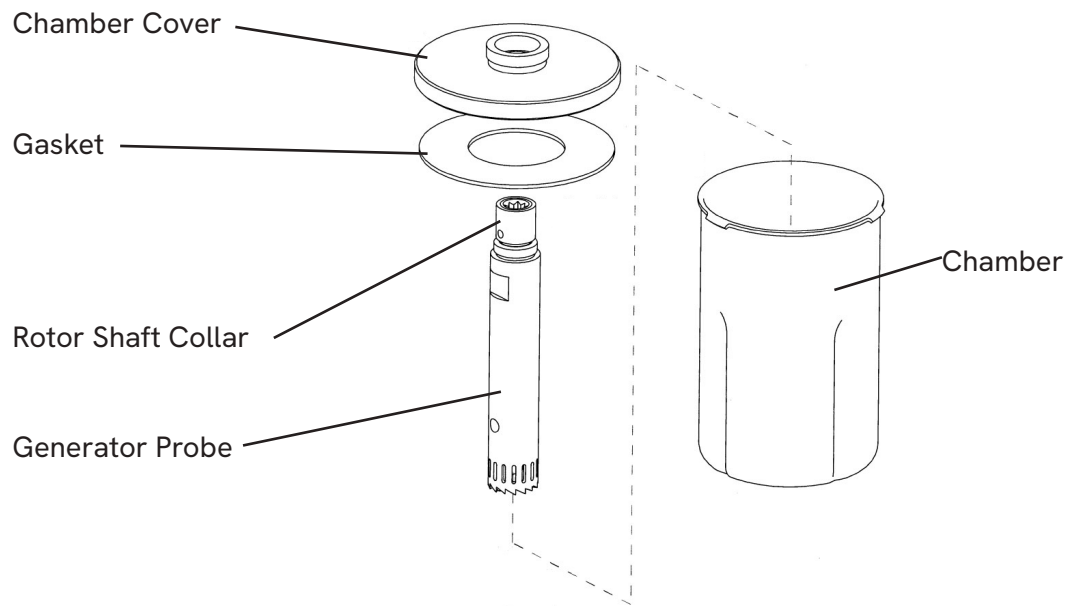

Cooling a Vessel

At speeds above 5,000 rpm relatively high chamber temperatures may be caused from friction during processing. Immersion of the chamber in an ice bath or cooling chamber is recommended.

WARNING: Never operate the motor with the sealed chamber assembly (or generator probe) partially threaded onto the motor. To prevent damage to the motor and attachments be sure that the sealed chamber assembly (or generator probe) is fully threaded into the coupling adapter. Failure to do so will result in damage to the coupling system.

Decontamination

Should an instrument or component that has been used with radioactive or pathogenic material require factory or field service, comply with the following procedure to ensure the safety of service personnel:

- Clean the parts to be serviced of all encrusted material and decontaminate them. There must be no radioactivity detectable by survey equipment.
- Obtain a Decontamination Certificate from Revvity. Complete the certificate and attach to the instrument or parts being returned.

If no Decontamination Certificate is attached, and a potential radioactive or biological hazard is detected or suspected by Revvity the equipment will not be serviced until proper decontamination and certification is complete. The sender will be contacted for instructions as to the disposition of the equipment. Disposition costs will be borne by the sender.

WARNING: It is a violation of federal law to transport biologically hazardous or radioactive materials without proper packaging, labeling, and appropriate warnings.

Maintenance

The motor drive housing can be cleaned periodically with a mild detergent. Never use solvents to clean the unit or accessories. While resistant to most laboratory chemicals, care should be taken to wipe off any concentrated and potentially damaging liquids.

Once per month the aluminum coupling adapter (see figure to right) of the homogenizer should be removed and cleaned. After cleaning, a good lubricant should be applied to the threads.

Motor Brush Maintenance

To a large measure, how well your homogenizer performs its job is determined by the condition of the carbon contact brushes (P/N 61810). If brushes require replacement, the unit may run at a reduced speed and make unusual noises, or it may run sporadically and lose power. If this occurs with your Mixer or Macro, unplug the cord, loosen the brush caps one at a time and check each brush. If the brushes are less than 1/8" long and the ends of the brushes (which contact the commutator) are rough and/or pitted, the brushes no longer make adequate contact with the commutator and should be replaced (check both brushes since both brushes generally do not wear at the same rate). If one brush is worn replace both brushes. Make sure that the brushes are installed properly. The brushes have a curved surface at the end which must match the curvature of the commutator. The curvature of the commutator is the same as the curvature of the motor housing.

If the brushes are not installed properly they will not contact the commutator and the motor will not run. After replacing the brushes, make sure to remove the flexible rubber coupling, place the motor on a clean surface, and run it freely (no-load, without a generator or chamber assembly attached) for 15 to 30 minutes before using the unit to process samples. This will allow the brushes to "seat" properly and will extend the life of each set of brushes. This will also extend the total life of your motor since the commutator surface will wear evenly.

Removal of Aluminum Coupling

In the event that the motor drive connect and/or the flexible rubber coupling needs to be serviced or replaced, the aluminum coupling can be removed using the following procedure:

1. Unplug motor unit from the wall.
2. Insert flat edge of combination wrench (included in motor tool kit) into the slots of the Quick Connect coupling (see figure to right).
3. Using wrench for leverage, loosen Quick Connect coupling by twisting it counter-clockwise.

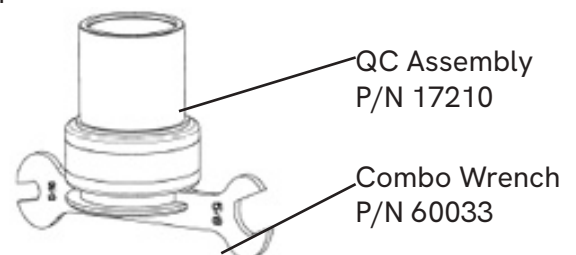

Installation of the coupling is the reverse of these steps.

Bearings and Lubrication

Motors are equipped with sealed ball bearings. Under normal use they require no additional lubrication. A tube of lubricant (PN 61971) is included with every drive unit and should be used to lubricate the threads of all connecting threaded parts, as well as the drive pin at the tip of the floating shaft. Lubricant should not be used to lubricate moving parts or bearings.

Grounding Instructions

In the event of a malfunction or breakdown, grounding provides a path of least resistance for electric current to reduce the risk of electric shock. This instrument is equipped with an electric cord which is grounded to the chassis housing. The plug must be plugged in to an outlet that is properly installed and grounded in accordance with all local codes and ordinances.

Troubleshooting

Problem	Corrective Action
The Mixer/Macro is plugged in and turned on but is not functioning.	<ul style="list-style-type: none"> - Check power cord connectors. - Check wall socket for power to the outlet.
Motor is turned ON and makes a “buzzing” sound, but is not working.	<ul style="list-style-type: none"> - Brushes may need to be replaced. Contact Revvity.
Motor unit operating speed declines, stalls intermittently, or stops completely.	<ul style="list-style-type: none"> - Brushes may need to be replaced. Contact Revvity.
PTFE bearing wears quickly.	<ul style="list-style-type: none"> - Fluid level may be too low in the tube. - Immerse the probe deeper into the fluid.
Excessive splashing in sample tube.	<ul style="list-style-type: none"> - Fluid level too low for tube size.

WARNING: Any service must be performed by a qualified service technician. This can be either an Revvity Technician or an end user resource.

All parts need to be sourced from the Revvity service department.

Appendix

This equipment is marked with the crossed-out wheeled bin symbol, to indicate that this equipment may not be disposed of as unsorted municipal waste.

It’s your responsibility to correctly dispose of your equipment at life-cycle end, by handing it over to an authorized facility for separate collection and recycling of waste equipment. It’s also your responsibility to decontaminate your equipment in case of biological, chemical or radiological contamination, and so protect the persons involved in the disposal and recycling of the equipment from health hazards.

For more information about where you can dispose of your waste equipment, please contact your local dealer, from whom you purchased the equipment.

By doing so, you will help to preserve natural and environmental resources and you will ensure that your equipment is recycled in a manner that protects human health.





The information provided in this document is for reference purposes only and may not be all-inclusive. Revvity, Inc., its subsidiaries, and/or affiliates (collectively, "Revvity") do not assume liability for the accuracy or completeness of the information contained herein. Users should exercise caution when handling materials as they may present unknown hazards. Revvity shall not be liable for any damages or losses resulting from handling or contact with the product, as Revvity cannot control actual methods, volumes, or conditions of use. Users are responsible for ensuring the product's suitability for their specific application. REVVITY EXPRESSLY DISCLAIMS ALL WARRANTIES, INCLUDING WARRANTIES OF MERCHANTABILITY OR FITNESS FOR A PARTICULAR PURPOSE, REGARDLESS OF WHETHER ORAL OR WRITTEN, EXPRESS OR IMPLIED, ALLEGEDLY ARISING FROM ANY USAGE OF ANY TRADE OR ANY COURSE OF DEALING IN CONNECTION WITH THE USE OF INFORMATION CONTAINED HEREIN OR THE PRODUCT ITSELF.

www.revvity.com

revvity

For research use only. Not for use in diagnostic procedures.

Revvity, Inc.
940 Winter Street
Waltham, MA 02451
USA
www.revvity.com

For a complete listing of our global offices, visit www.revvity.com
Copyright ©2024, Revvity, Inc. All rights reserved.