

B / u PAD

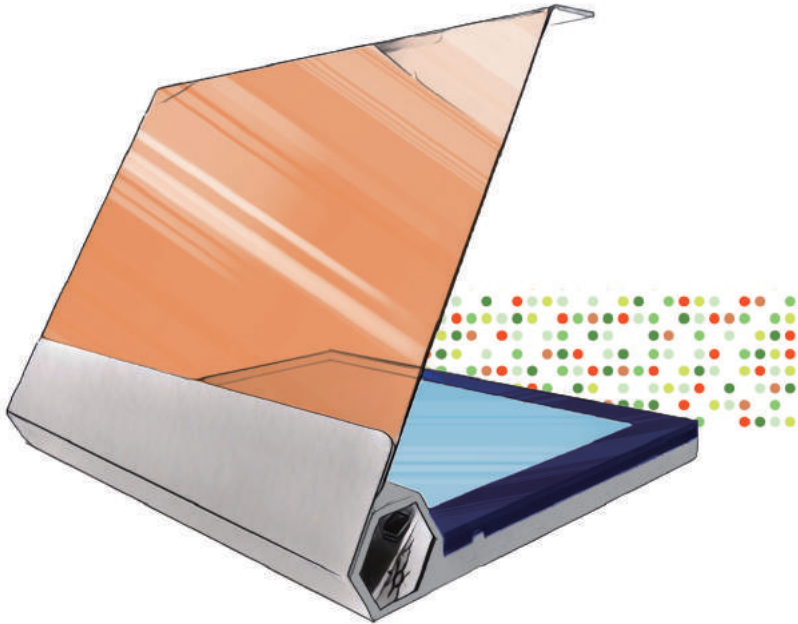

BluPAD Dual LED Blue / White Light Transilluminator

Catalog number: BP001CU

Contents

* Description	01
* Mode	02
Blue Light Mode	02
White Light Mode	02
Field Study Mode	02
* Features	03
* Specifications	04
* Contents	04
* Operation Instruction	05
Blue Light Mode – Gel Cutting	05 / 06
Blue Light Mode – Imaging	07 / 08
White Light Mode	09 / 10
* Troubleshooting	11
* Related Ordering Information	12
* Maintenance and Repair	13
Cleaning and Maintenance	13
Method of Replacing with the New Blade	13
Replacement of Spare Parts	13
Servicing	14
REGULATORY NOTICE	14
* Appendix	15
Explanation of Symbols and Warnings	15
Caution	15
Warranty	15
Safety Information	16
Manufacturer	16

01 Description

The BluPAD, as an innovatively designed transilluminator with dual light sources, is applicable in various Life Sciences research areas for observing and analyzing the nucleic acids and proteins. Given its most optimal and humanized design for the post-observation applications, such as gel cutting and data imaging and filing, it is desired to provide the researchers with a brand-new comfortable, convenient, and safe experience.

O2 Mode

Blue Light Mode

With the 470nm LED light wavelength as the excitation light source (Figure 1.), the Blue Light mode is applied for observing the qualitative and quantitative nucleic acid or protein experiments using the fluorescent staining reagents. Other than being compatible with our safe reagents, such as the Novel Juice, Novel Green, Novel Green Plus, OnePCR series, Nimble Juice, Nimble Juice R-TYPE, it also performs well with a majority of fluorescent staining products on the market, such as SYBR Gold, SYBR Green I & II, SYPRO Ruby, SSYPRO Orange, Coomassie Fluor Orange, GelStar, and GelGreen stains, GelStar, GelGreen. The feature of allowing light intensity adjustment at three different levels enables the user to make the light intensity contrast adjustment based on the sample concentration for achieving the best imaging quality. Further, the magnetic amber filter, with the hinges-free design, offers simplicity, safety, and convenience when opening and closing the filter.

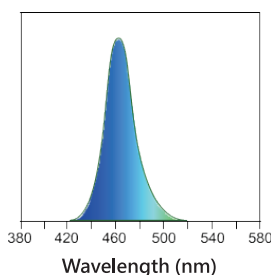

Figure 1.
Excitation and Emission Spectra for BluPAD
Dual LED Blue / White Light Transilluminator.

White Light Mode

By using the whole-wavelength white LED light as the excitation light source, the White Light mode exhibits softness and uniformity and is applicable for observing or imaging the SDS-PAGE gels that are stained with the Coomassie Blue or Silver Stain. It can also be employed as a simple film-viewing transilluminator for checking the X-Ray film for the research or clinical purpose. With the light intensity adjustment function, the contrasting adjustment of the light intensity is enabled at three levels according to the observational requirements for achieving the best imaging quality.

Field Study Mode

Connectable with the external power bank for the hassle-free field experiments.

* The power bank is NOT INCLUDED in the package and needs to be purchased by the user.

03 Features

Dual Light Sources - LED White Light and Blue Light

Broad ranges of applicability and compatibility in basic science and medical diagnosis research fields.

Magnetic Filter

The hinges-free design offers simplicity, safety, and convenience to the user and will not cause any damage to the filter near the hinges. Conducting the observation and gel-cutting does not require the protective goggles.

Bottom-Up LED Illumination

It prevents the interference from the reflective lights that are caused by the side illumination, thus improving the observational and imaging quality. Since the LED lights are durable and safe, it does not cause damage to the eyes and skin or to the experiment sample as normally found with the UV illumination.

Adjustable Light Intensity (3 Levels)

Adjusting the light intensity and contrast based on the sample quantity or observational requirement will achieve the best observational or imaging quality.

5-Minute Automatic Power-Off

It protects the transilluminator from the risk that is caused by the user's operational negligence.

Designer Metal Housing

The transilluminator's base is rendered more stable, thus facilitating the operational process.

Exquisite and Compact Design

It offers the ease of mobility and storage and is suitable for the experimental observation during the field study.

Enhanced Portability with the Power Bank

Hassle-Free for performing the outdoor experiments.

* The power bank is NOT INCLUDED in the package and needs to be purchased by the user.

04 Specifications

Unit Dimensions (W*L*H) : 18.5 x 22 x 3cm

Gel Viewing Dimensions (W*L) : 12 x 18cm

Input Voltage : 100-240Vac

Input Current : 2.0A

LED Source : Built-in LED blue light & white light modules.

LED Life (hours) : >30,000

Emission Maxima (nm) : 470nm

Store Temperature : 25°C

Automatic Power-Off : 5 mins

Filter Type : Amber filter (580nm)

Certifications : CE / ETL

05 Contents

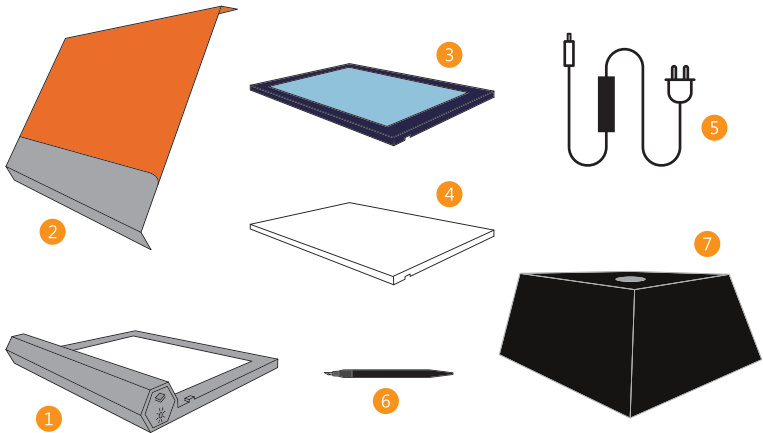

- 1 Dual LED Blue / White Light Transilluminator Base
- 2 Amber Filter Cover
- 3 Blue Uniform Plate w Glass
- 4 White Uniform Plate
- 5 Power Cord
- 6 Gel-Cutting Knife and Replacement Blade
- 7 miniDarkroom

06 Operation Instruction

Blue Light Mode – Gel Cutting

- 1 Place the BluPAD Dual LED Blue / White Light Transilluminator on a level operational bench, with enough space around the unit for allowing air circulation and preventing overheating.
- 2 Connect the power cord to the power socket.
- 3 Press the ON / OFF switch to the Blue Light Mode.
- 4 Place the blue filter (including the scratch-proof glass) in position.
- 5 Position the amber filter at an angle of 60 degrees for magnetically connecting with the transilluminator's base.
- 6 Upon placing the gel sample in the transparent glass area of the blue filter, the gel-observing and cutting experiment can be immediately conducted.

Caution :
For the automatic power-off feature at 5 minutes, please press the power switch again to switch on the indicator light once the LED indicator light is off.
Press the light intensity adjustment button based on the sample condition.
- 7 Upon completing the operation, turn the transilluminator off.
- 8 Please use the clean and wet cotton cloth to wipe the surfaces of the transilluminator and filter.

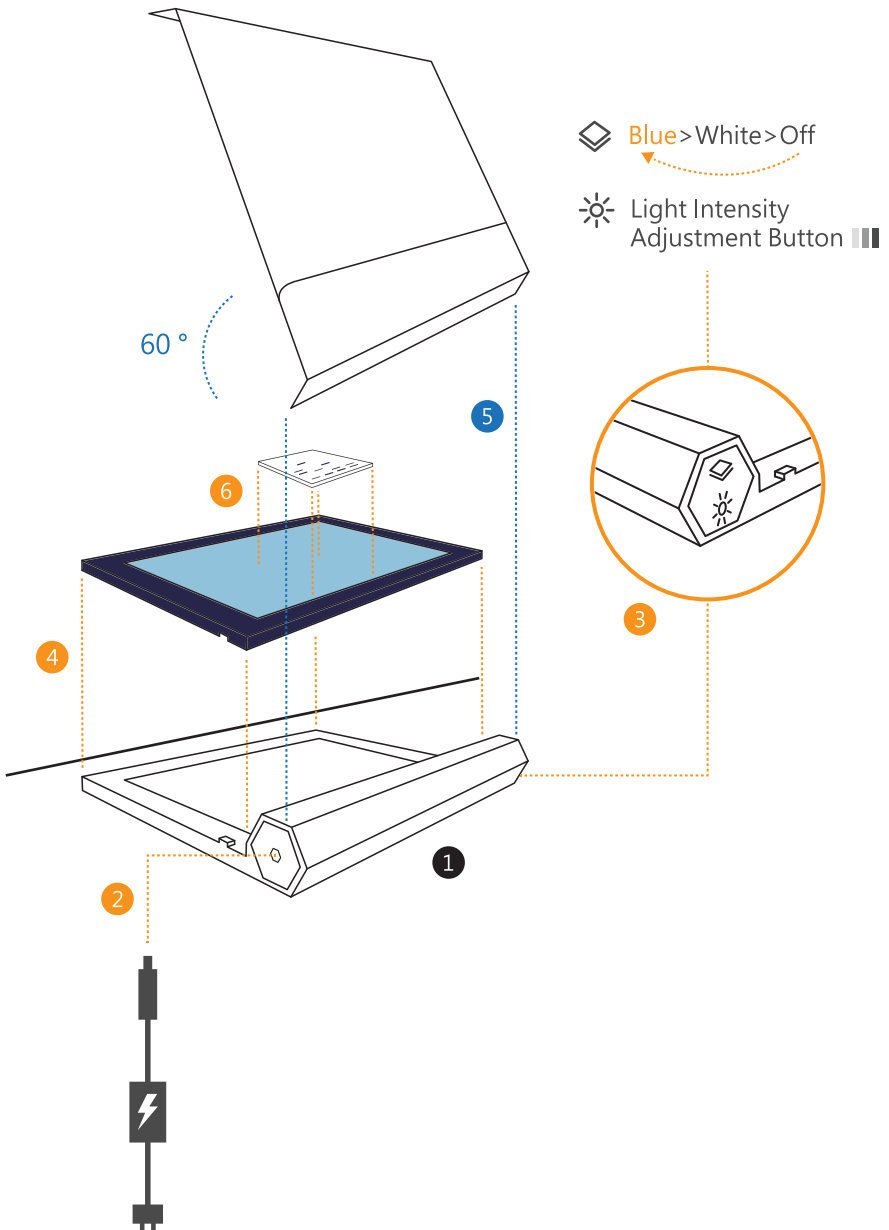

Blue Light Mode - Imaging

- 1 Place the BluPAD Dual LED Blue / White Light Transilluminator on a level operational bench, with enough space around the unit for allowing air circulation and preventing overheating.
- 2 Connect the power cord to the power socket.
- 3 Press the ON / OFF switch to the Blue Light Mode.
- 4 Place the blue filter in position (including the scratch-proof glass).
- 5 Upon placing the gel sample in the transparent glass area of the blue filter, the gel-observing and cutting experiment can be immediately conducted.

Caution :

For the automatic power-off feature at 5 minutes, please press the power switch again to switch on the indicator light once the LED indicator light is off.

- 6 Position the amber filter at an angle of 0 degree for magnetically connecting with the transilluminator's base.
- 7 Upon placing the miniDarkroom on the top of the amber filter, observation and imaging can be performed immediately.
- 8 Please switch off the power upon completing the operation.
- 9 Please use the clean and wet cotton cloth to wipe the surfaces of the transilluminator and filter.

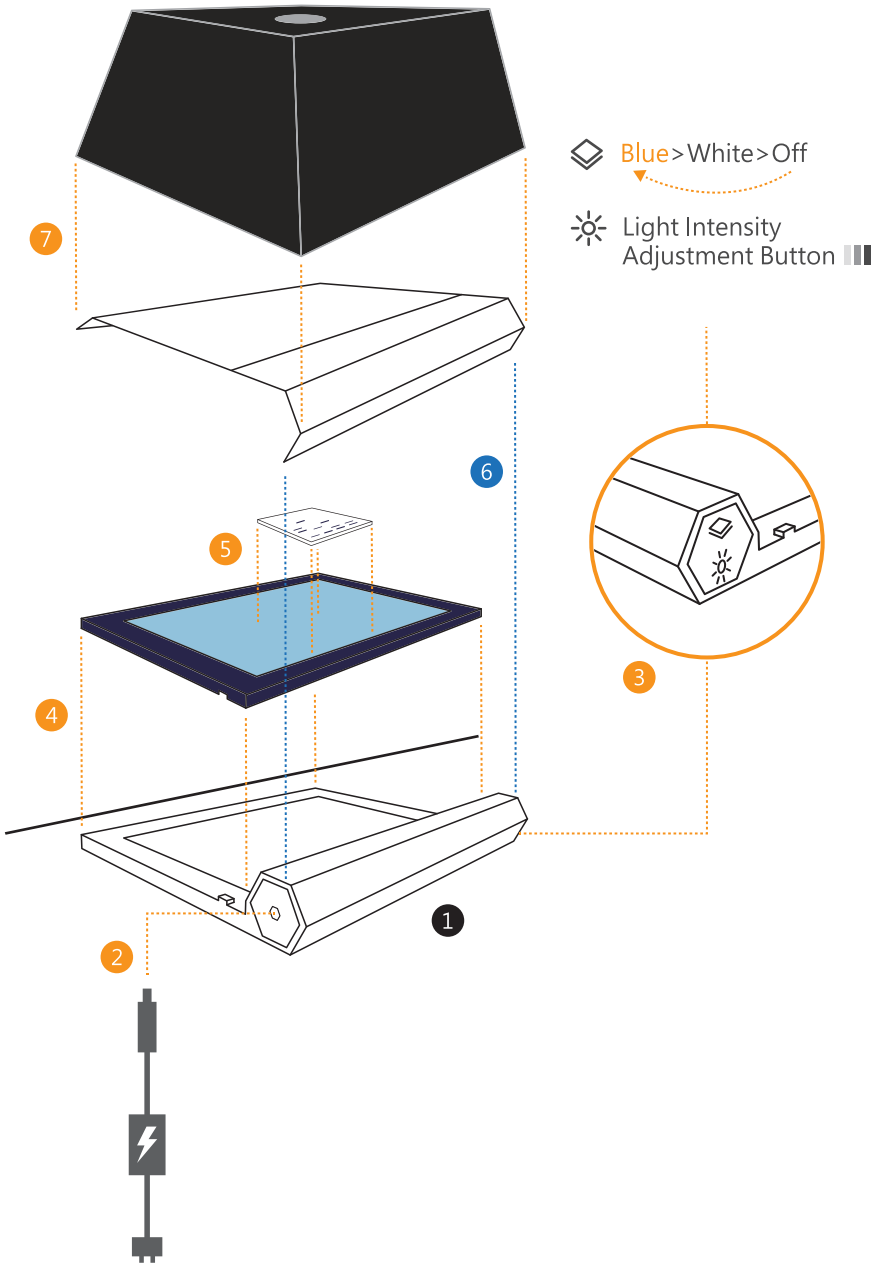



White Light Mode

- 1 Place the BluPAD Dual LED Blue/White Light Transilluminator on a level operational bench, with enough space around the unit for allowing air circulation and preventing overheating.
- 2 Connect the power cord to the power socket.
- 3 Press the ON / OFF switch to the White Light Mode.
- 4 Place the white filter in position.
- 5 Upon placing the gel sample or X-ray film in the white filter area, gel-observation can be immediately conducted.

Caution :

For the automatic power-off feature at 5 minutes, please press the power switch again to switch on the indicator light once the LED indicator light is off.

 Blue>White>Off

 Light Intensity
Adjustment Button 

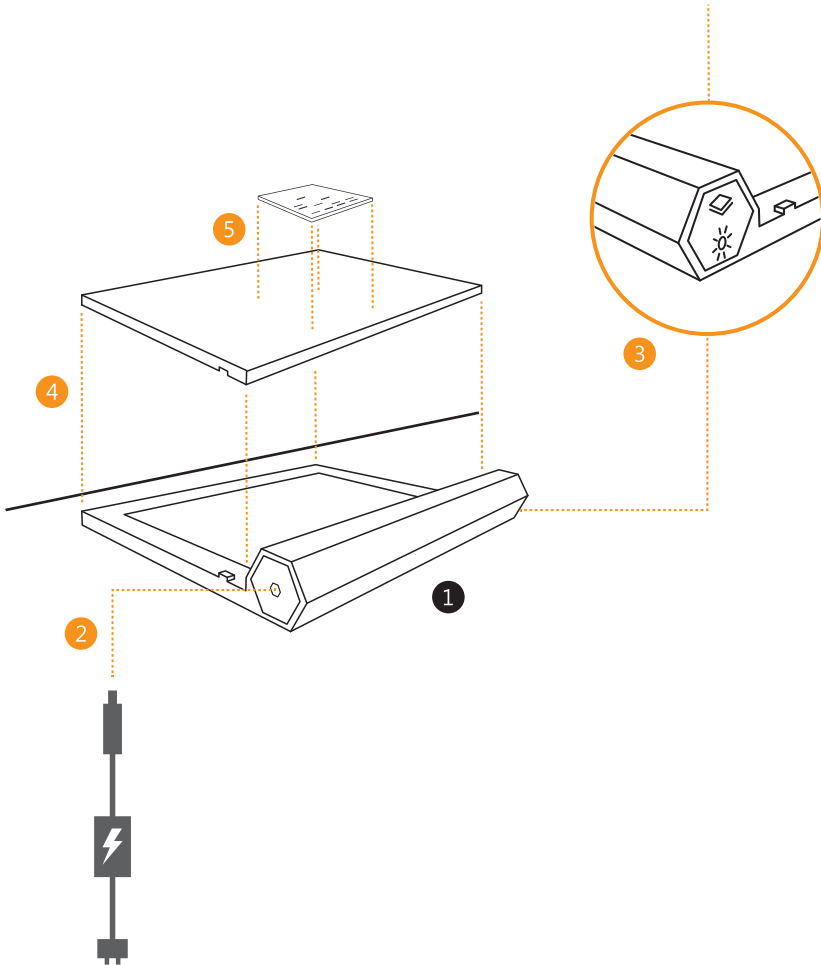

07 Trouble-Shooting

Refer to the table below to troubleshoot problems that you may encounter when viewing with the BluPAD Dual LED Blue / White Light Transilluminator.

Problem	Cause	Solution
Low sensitivity.	<ul style="list-style-type: none">* The fluorescent staining reagents selected and used do not exhibit wavelengths within the 400nm - 450nm range.* Insufficient sample concentration.	<ul style="list-style-type: none">* Replace the fluorescent staining reagent.* Adjust the light intensity and check for improvement. Please increase the sample concentration if no improvement is observed.
The sample is not observed under the Blue Light Mode.	Incorrect light source.	Please confirm the selected light source is the blue light, NOT the WHITE Light.

08 Related Ordering Information

Cat. No.	Description
BP001CU	BluPAD Dual LED Blue/White Light Transilluminator
BP-miniDR	BluPAD miniDarkroom
BP-KNIFE	BluPAD Gel-Cutting Knife
BP-AFC	BluPAD Upper Amber Filter Cover
BP-WUP	BluPAD White Uniform Plate
BP-BDPG	BluPAD Blue Uniform Plate W Glass
BP-AC	BluPAD 60 Watt Adaptor

Note :

Please read the installation instruction carefully before installing the BluPAD Dual LED Blue/White Light Transilluminator. This instrument is intended for clinical and research laboratory use and it must be operated only by specialized personnel aware of the potential risks associated with the chemical and biological agents normally used with this unit. This instrument is meant for use only by specialized personnel that know the health risks associated with blue light radiation and with reagents that are normally used with this instrument. It is designed to shield only the person working in front of the system and to observe the gel fluorescence emission clearly.

09 Maintenance and Repair

Cleaning and Maintenance

The transilluminator should be damply wiped off with a soft cotton cloth. The cloth should not be too wet. Do not use aggressive cleaning detergents or solvents.

After use of the transilluminator, we recommend to wipe off the frame and the filter glass with a damp cloth. Take care that the cloth is not soaked with scrubbing or corrosive detergents as this could damage the filter glass. We suggest using alcohol, glass cleaners or similar mild detergents.

Pay attention to wearing appropriate gloves when cleaning areas (such as the filter plate of the transilluminator, switches, protection shield) which may have been in contact with carcinogenic or toxic reagents. The protection shield is made of tempered glass and must only be cleaned with a damp cloth.

Method of Replacing with the New Blade

When replacing with the new blade, unscrew the silver handling part of the knife counterclockwise from the head part. Push out the head part's blade-holding section. Remove the old blade, and open the "SPARE BLADE" for taking out the new replacement blade. Insert it into the X-shaped blade insertion hole. Restore the silver connector back into the original position, and then screw tight the head part with the silver handling part clockwise.

Caution :

The blade is quite sharp. Please act with caution to avoid cuts.

Replacement of Spare Parts

Only original spare parts are allowed.

Servicing

Please contact your local dealer.

The BluPAD Dual LED Blue / White Light Transilluminator is warranted against defects in materials and workmanship for 1 year. If any defects occur in the instrument or accessories during this warrant period, Bio-Helix will repair or replace the defective parts at its discretion without charge. The following defects, however, are specifically excluded :

- 1 Defects caused by improper operation.
- 2 Repair or modification done by anyone other than Bio-Helix or an authorized agent.
- 3 Damage caused by substituting alternative parts.
- 4 Use of fittings or spare parts supplied by anyone other than Bio-Helix.
- 5 Damage caused by accident or misuse.
- 6 Damage caused by disaster.
- 7 Corrosion caused by improper solvent or sample.

For any inquiry or request for repair service, contact your local Bio-Helix office. Inform the model and serial number of your instrument.

REGULATORY NOTICE

IMPORTANT :

This Bio-Helix instrument is designed and certified to meet safety standards. Certified products are safe to use when operated in accordance with the instruction manual. This instrument should not be modified or altered in any way.

Alteration of this instrument will :

- 1.Void the manufacturer's warranty
- 2.Void the safety and EMC certification
- 3.Create a potential safety hazard

Bio-Helix is not responsible for any injury or damage caused by the use of this instrument for purposes other than those for which it is intended, or by modifications of the instrument not performed by Bio-Helix or an authorized agent.

10 Appendix

Explanation of Symbols and Warnings

BluPAD Dual LED Blue / White Light Transilluminator complies with the European Community Safety requirements. A CE Marking is a European marking of conformity that indicates a product complies with the essential requirements of the applicable European laws or directives with respect to safety, health, and environment and consumer protection. Generally, this conformity to the applicable directives is done through self-declaration. The CE Marking is required on products in the countries of the European Economic Area (EEA) to facilitate trade among the member countries. The manufacturer or their authorized representative established in the EEA is responsible for affixing the CE Marking to their product. The CE Marking provides a means for a manufacturer to demonstrate that a product complies with a common set of laws required by all of the countries in the EEA to allow free movement of trade within the EEA countries.

Caution

Caution risk of danger.

Consult the User Guide for further safety information.

Do not dispose of this product in unsorted municipal waste.

To minimize negative environmental impact from disposal of electronic waste, do not dispose of electronic waste in unsorted municipal waste. Follow local municipal waste ordinances for proper disposal provision and contact customer service for information about responsible disposal options.

Warranty

Bio-Helix warrants that BluPAD Dual LED Blue / White Light Transilluminator will be free from defects in material and workmanship for a period of one year from date of purchase. If a defect is present, Bio-Helix will, at its option, repair, replace, or refund the purchase price of this product at no charge to you, provided it is returned during the warranty period. This warranty does not apply if the product has been damaged by accident, abuse, misuse or misapplication, or from ordinary wear and tear. This warranty shall be limited to the replacement of defective products. It is expressly agreed that this warranty will be in lieu of all warranties of fitness and in lieu of the warranty of merchantability.

Safety Information

The BluPAD Dual LED Blue / White Light Transilluminator is an electrical device. Never touch the power cord or outlet with wet hands. Do not use this device in damp areas or while standing on damp floors. Do not attempt to open the BluPAD Dual LED Blue / White Light Transilluminator. The BluPAD Dual LED Blue / White Light Transilluminator should be used with the supplied power cord. Only these power cords should be used to power the device. Attach the power cord to the BluPAD Dual LED Blue / White Light Transilluminator. Plug the other end of the power cord into a properly grounded electrical outlet, ensuring the correct plug adaptor is attached. Always disconnect the BluPAD Dual LED Blue / White Light Transilluminator from the electrical outlet before cleaning the device. The BluPAD Dual LED Blue / White Light Transilluminator does not produce UV-light; however, it does utilize an intense blue light for viewing gels. It should be noted that published literature has identified blue light as a possible risk factor for macular degeneration; however, no clinical studies have been published. Therefore, the BluPAD Dual LED Blue / White Light Transilluminator amber filter unit provided with this device should be used to protect your eyes while viewing gels. The amber filter unit is NOT a safety screen for UV emission, and will NOT protect your eyes when viewing gels on UV transilluminators. After viewing and documenting the gel or sample, always press the unit off.

Please position and use the BluPAD Dual LED Blue/White Light Transilluminator on the level laboratory benchtop. If the transilluminator is positioned on the unlevelled laboratory benchtop or platform, it may cause the sample gel to slide, thus making the user unable to observe the gel. After the LED transilluminator is switched on for 5 minutes, the automatic disconnecting device will automatically switch off the power source.

Manufacturer

Bio-Helix Co., Ltd.

Room MAF 312, No.2, Beining Rd., Keelung City Taiwan (202), TAIWAN

Tel : +886-2-24624956

E-mail : info@bio-helix.com

Website : www.bio-helix.com



